

# FDU

Indoor Unit

Duct Connected -High Static pressure-



FDU 71/100/125/140



**New** FDU 200/250/280

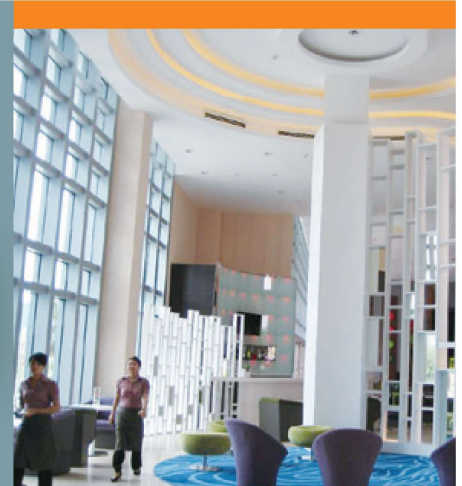

- ECO Energy Saving
- Automatic Operation
- Silent Operation
- Hi Power
- Weekly/Sleep/Peak-Cut Timer
- Self-Diagnostics



Remote control (option)

Wired			Wireless	
RC-EX3A RC-EXZ3A	RC-E5	RCH-E3	RCN-KIT4-E2	

\*Not all functions available with all remote control options.

## External Static Pressure (E.S.P.) Control

The External Static Pressure (E.S.P.) can be manually set on the wired remote controller. Indoor unit will control the fan speed to keep rated air flow volume at each fan speed setting. You can set required E.S.P. by wired remote controller, calculated with the set air flow rate and the pressure loss of the duct.

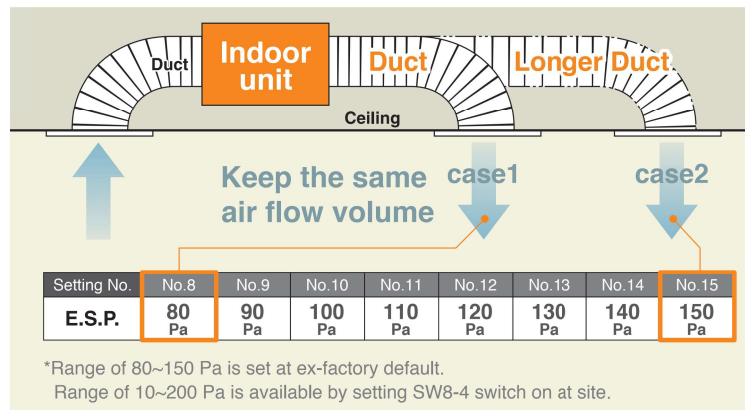

Expansion of external static pressure range

Previous 10~130Pa

↓

Current 10~200Pa

### RC-E5

#### E.S.P. button

External Static Pressure (E.S.P.) can be set by E.S.P. button.



## Motion Sensor (Option)

**New**

Motion sensor is equipped in the ceiling plane or wall plane and detects the presence/absence and activity of humans in a room to improve the comfort and energy saving performance of the unit.



LB-KIT2

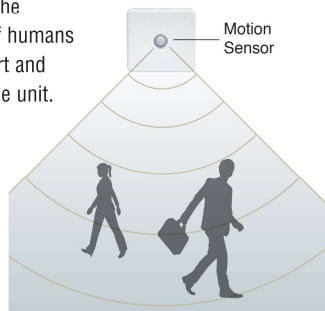

## High Efficiency

Energy efficiency is improved by use of DC fan motor & high efficient heat exchanger.

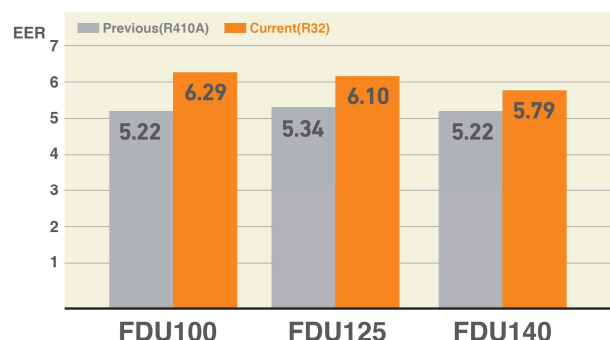

## Zoning system

Effectively control temperatures of multiple rooms with one indoor duct unit.

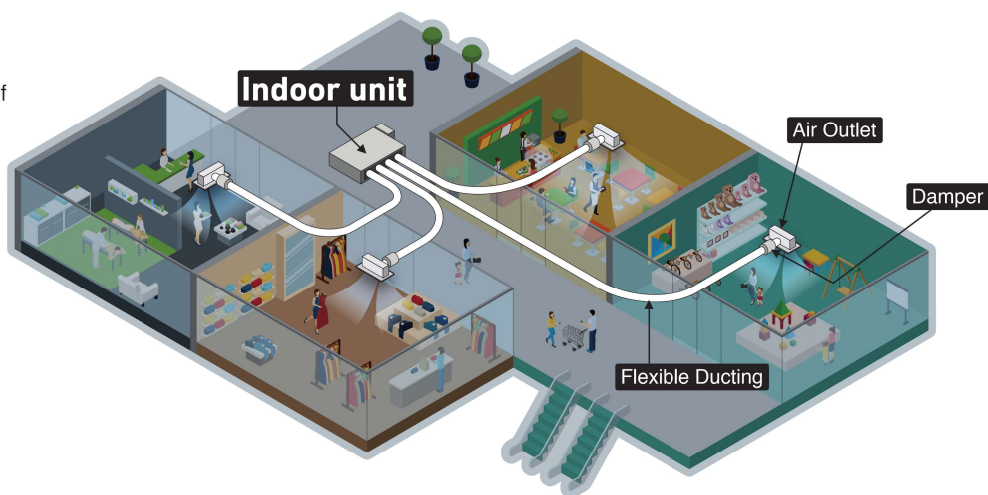

## Zone control function (Available for FDU71-140 and FDUM40-140)

These models have a zone control function that can control up to four zones. The zones consist of one (\*1) common zone and up to three (\*2) spill zones. The damper of each zone can be opened or closed with the exclusive remote control (RC-EXZ3A). Timer function to open/close the damper is also available.

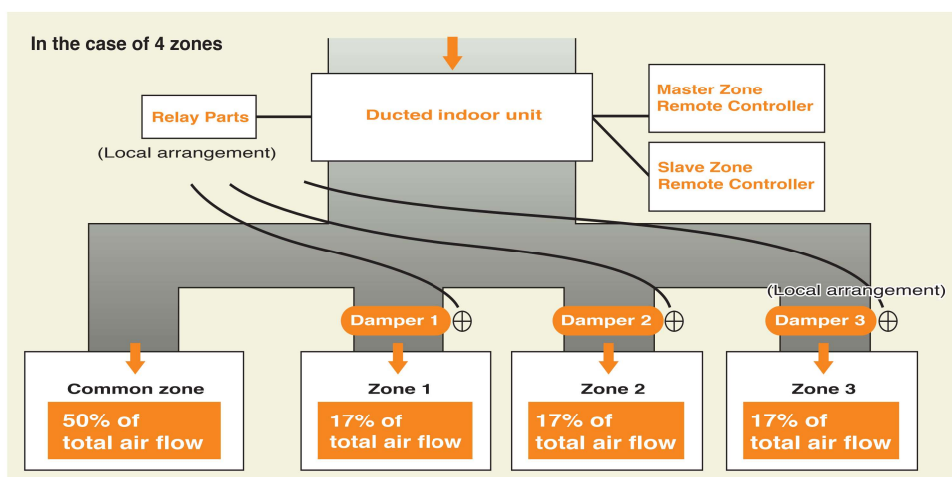

### RC-EXZ3A

Top display

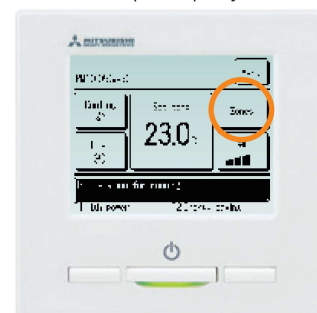

Zone menu

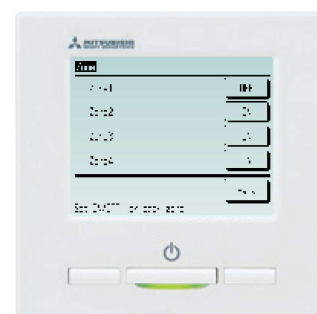

Notes:

\*1: Common zone; A zone in which a damper is not installed.

\*2: Spill zone; A zone in which a damper open automatically.

Cannot control more than 4 zones.

Procure relevant parts such as relay parts, dampers, ducts, and wirings locally.

Design the duct so that each the common zone and the spill zones equal 50% of total air flow.

Ducts in the spill zones should have equal static pressure.

## Round Duct Adapter (Available for FDU71~140 and FDUM40~140)



Company: AIRZONE  
URL: <http://www.airzone.es>

All-in-one solution: the whole zoning system in a plug&play device perfectly adapted to the indoor DX unit

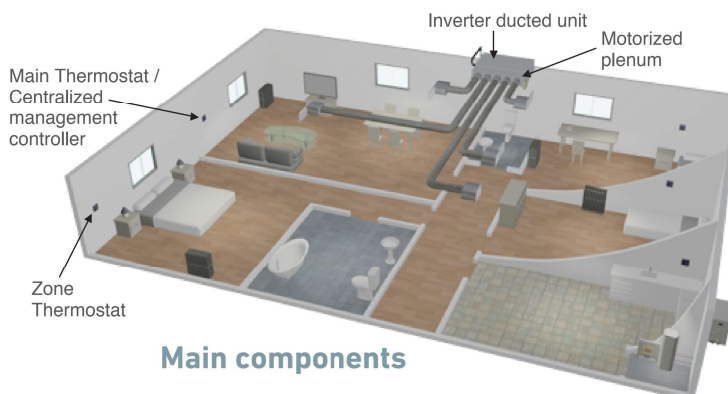
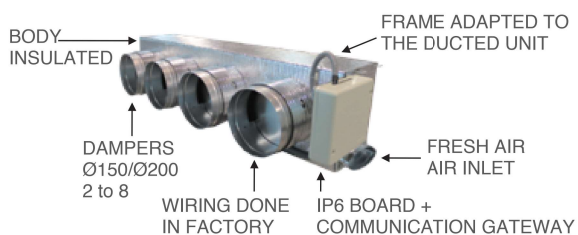

Main components

## Enhanced Installation Workability

600mm Drain Pump is mounted in FDU71/100/125/140. The indoor unit is completely hidden in the ceiling, so this is suitable for spaces with classy interior decoration.

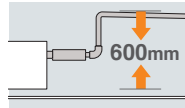

## Improvement of the Serviceability

Fan unit (impeller and motor) can be pulled out from the right side of the unit. Maintenance can be carried out from the right side or the bottom side of the unit.

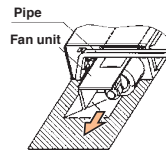

## Transparent Inspection Window

Dirt condition of the bottom of a drain pan can be checked through this transparent inspection window without removing drain pan.

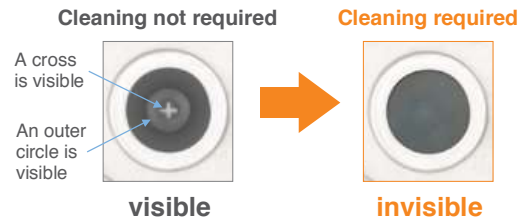

## OUTDOOR UNIT

		Hyper Inverter	
FDC		71VNX-W	100~140VN(S)X-W
		71VNX	100~140VN(S)X
model			
Chargeless		30m	
Height x Width x Depth (mm)		750 x 880(+88) x 340	1,300 x 970 x 370

		Micro Inverter			Standard Inverter		
FDC		100~140VN(S)A-W	—	200·250·280VSA-W	71VNP-W	90·100VNP-W	—
		100~140VN(S)A	200VSA	250VSA	71VNP	90VNP1	100VNP
model							
Chargeless		30m			15m		
Height x Width x Depth (mm)		845 x 970 x 370	1,300 x 970 x 370	1,505 x 970 x 370	640 x 800(+71) x 290	750 x 880(+88) x 340	845 x 970 x 370

## DIMENSIONS (Unit:mm) - FDU -

### Model FDU71VH

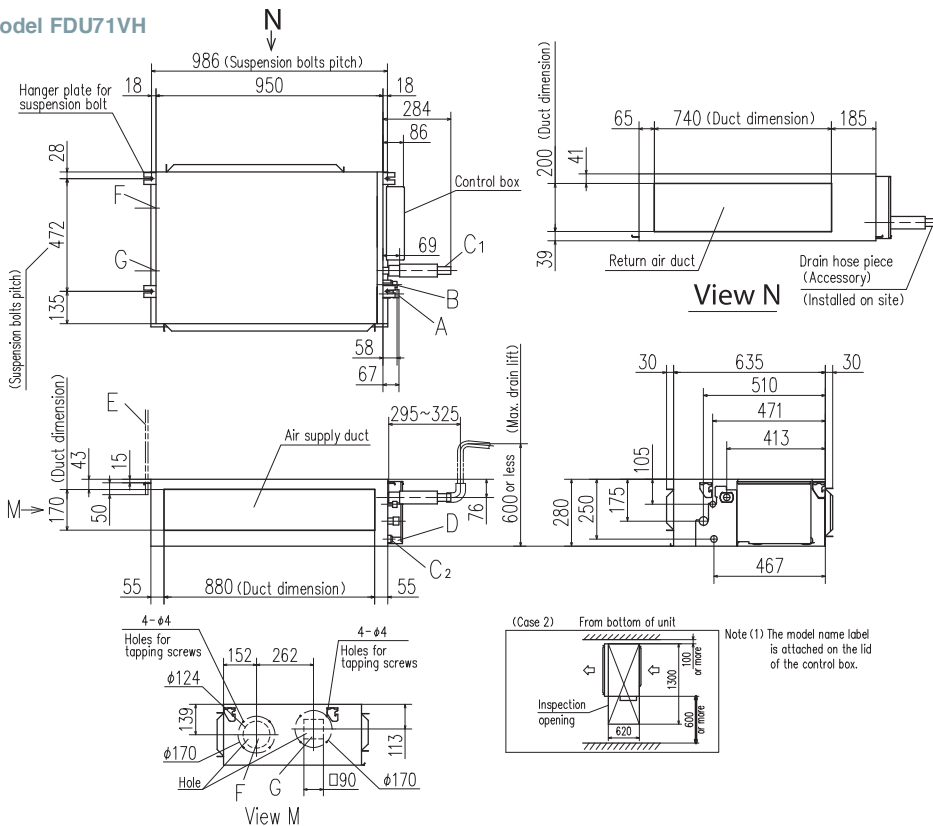

Symbol	Content
A	Gas piping φ15.88 (5/8") (Flare)
B	Liquid piping φ9.52 (3/8") (Flare)
C1	Drain piping VP25 (O.D.32)
C2	Drain piping (Gravity drainage) VP20
D	Hole for wiring
E	Suspension bolts M10
F	Outside air opening for ducting (Knock out)
G	Air outlet opening for ducting (Knock out)
H	Inspection opening (450X450)

#### Space for installation and service

Select either of two cases to keep space for installation and services.  
(Case 1) From side of unit

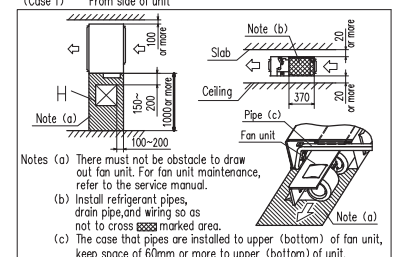



## SPECIFICATIONS -FDU-

R32			Hyper Inverter				
Set model name			FDU71VNXXVWH	FDU100VNXXVWH	FDU125VNXXVWH	FDU140VNXXVWH	
Indoor unit			FDU71VH	FDU100VH	FDU125VH	FDU140VH	
Outdoor unit			FDC71VNX-W	FDC100VNX-W	FDC125VNX-W	FDC140VNX-W	
Power source			1 Phase 220-240V, 50Hz / 220V, 60Hz				
Nominal cooling capacity (Min~Max)			kW 7.1 (3.2 ~ 8.0)	10.0 (3.5 ~ 11.2)	12.5 (3.5 ~ 14.0)	14.0 (3.5 ~ 16.0)	
Nominal heating capacity (Min~Max)			kW 8.0 (3.6 ~ 9.0)	11.2 (2.7 ~ 12.5)	14.0 (2.7 ~ 17.0)	16.0 (2.7 ~ 18.0)	
Power consumption			Cooling/Heating kW 1.77 / 1.78	2.59 / 2.63	3.49 / 3.61	4.22 / 4.22	
EER/COP			Cooling/Heating 4.01 / 4.49	3.86 / 4.26	3.58 / 3.88	3.32 / 3.79	
Inrush current			A 5				
Max. current			A 20				
Sound power level*1	Indoor	Cooling/Heating	65 / 65	65 / 65	67 / 67	70 / 70	
	Outdoor	Cooling/Heating	66 / 66	67 / 67	68 / 70	69 / 71	
Sound pressure level*1	Indoor	Cooling (P-Hi/Hi/Me/Lo)	dB(A) 38 / 33 / 29 / 25		44 / 38 / 36 / 30	45 / 40 / 34 / 29	47 / 40 / 35 / 30
		Heating (P-Hi/Hi/Me/Lo)	38 / 33 / 29 / 25		44 / 38 / 36 / 30	45 / 40 / 34 / 29	47 / 40 / 35 / 30
	Outdoor	Cooling/Heating	51 / 51		53 / 51	53 / 54	54 / 54
		Cooling (P-Hi/Hi/Me/Lo)	m³/min 24 / 19 / 15 / 10		36 / 28 / 25 / 19	39 / 32 / 26 / 20	48 / 35 / 28 / 22
Air flow	Indoor	Heating (P-Hi/Hi/Me/Lo)	24 / 19 / 15 / 10		36 / 28 / 25 / 19	39 / 32 / 26 / 20	48 / 35 / 28 / 22
		Cooling/Heating	60 / 50		100 / 100	100 / 100	100 / 100
External static pressure*2			Pa Standard:35 Max:200	Standard:60 Max:200			
Exterior dimensions	Indoor	HeightxWidthxDepth	mm 280 x 950 x 635		280 x 1,370 x 740		
	Outdoor		750 x 880(+88) x 340		1,300 x 970 x 370		
Net weight	Indoor		kg 34		54		
	Outdoor		60		97		
Ref.piping size			Liquid/Gas ømm 9.52(3/8") / 15.88(5/8")				
Refrigerant line (one way) length			m Max.50		Max.100		
Vertical height differences			Outdoor is higher/lower m Max.30 / Max.15		Max.50 / Max.15		
Outdoor operating temperature range	Cooling	°CDB	-15~50*3				
	Heating	°CWB	-20~20				
Air filter			Procure locally				
Remote control (option)			wired:RC-EX3A, RC-E5, RCH-E3 wireless:RCN-KIT4-E2				

R32			Hyper Inverter			
Set model name			FDU100VSXWVH	FDU125VSXWVH	FDU140VSXWVH	
Indoor unit			FDU100VH	FDU125VH	FDU140VH	
Outdoor unit			FDC100VSX-W	FDC125VSX-W	FDC140VSX-W	
Power source			3 Phase 380-415V, 50Hz / 380V, 60Hz			
Nominal cooling capacity (Min~Max)			kW 10.0 (3.5 ~ 11.2)	12.5 (3.5 ~ 14.0)	14.0 (3.5 ~ 16.0)	
Nominal heating capacity (Min~Max)			kW 11.2 (2.7 ~ 16.0)	14.0 (2.7 ~ 18.0)	16.0 (2.7 ~ 20.0)	
Power consumption			Cooling/Heating kW 2.59 / 2.63	3.49 / 3.61	4.22 / 4.22	
EER/COP			Cooling/Heating 3.86 / 4.26	3.58 / 3.88	3.32 / 3.79	
Inrush current			A 5			
Max. current			A 15			
Sound power level*1	Indoor	Cooling/Heating	65 / 65		67 / 67	70 / 70
	Outdoor	Cooling/Heating	67 / 67		68 / 70	69 / 71
Sound pressure level*1	Indoor	Cooling (P-Hi/Hi/Me/Lo)	dB(A) 44 / 38 / 36 / 30		45 / 40 / 34 / 29	47 / 40 / 35 / 30
		Heating (P-Hi/Hi/Me/Lo)	44 / 38 / 36 / 30		45 / 40 / 34 / 29	47 / 40 / 35 / 30
	Outdoor	Cooling/Heating	53 / 51		53 / 54	54 / 54
		Cooling (P-Hi/Hi/Me/Lo)	m³/min 36 / 28 / 25 / 19		39 / 32 / 26 / 20	48 / 35 / 28 / 22
Air flow	Indoor	Heating (P-Hi/Hi/Me/Lo)	36 / 28 / 25 / 19		39 / 32 / 26 / 20	48 / 35 / 28 / 22
		Cooling/Heating	100 / 100		100 / 100	100 / 100
External static pressure*2			Pa Standard:60 Max:200			
Exterior dimensions	Indoor	HeightxWidthxDepth	mm 280 x 950 x 635		280 x 1,370 x 740	
	Outdoor		750 x 880(+88) x 340		1,300 x 970 x 370	
Net weight	Indoor		kg 34		54	
	Outdoor		60		99	
Ref.piping size			Liquid/Gas ømm 9.52(3/8") / 15.88(5/8")			
Refrigerant line (one way) length			m Max.50		Max.100	
Vertical height differences			Outdoor is higher/lower m Max.30 / Max.15		Max.50 / Max.15	
Outdoor operating temperature range	Cooling	°CDB	-15~50,*3			
	Heating	°CWB	-20~20			
Air filter			Procure locally			
Remote control (option)			wired:RC-EX3A, RC-E5, RCH-E3 wireless:RCN-KIT4-E2			

### NOTES:

The data are measured under the following conditions(R32:ISO-T1, -H1 / R410A:ISO-T1).  
Cooling:Indoor temp. of 27°CDB, 19°CWB, and outdoor temp. of 35°CDB. Heating:Indoor temp. of 20°CDB, and outdoor temp. of 7°CDB, 6°CWB.  
\*1 : Indicates the value in an anechoic chamber. During operation these values are somewhat higher due to ambient conditions.  
\*2 : External static pressure is changeable to be set by the remote control. MAX external static pressure is "High static pressure" setting. The values of sound pressure level become 5dB(A) higher at external static pressure of 200Pa.  
\*3 : If a cooling operation is conducted when the outdoor air temperature is -5°C or lower, the outdoor unit should be installed at a place where it is not influenced by natural wind. If wind blows, the low pressure will drop and compressor frequency will increase, this will cause the capacity to drop and may cause the unit to break down.

R410A			Hyper Inverter			
Set model name			FDU71VNXVH	FDU100VNXVH	FDU125VNXVH	FDU140VNXVH
Indoor unit			FDU71VH	FDU100VH	FDU125VH	FDU140VH
Outdoor unit			FDC71VNX	FDC100VNX	FDC125VNX	FDC140VNX
Power source			1 Phase 220-240V, 50Hz / 220V, 60Hz			
Nominal cooling capacity (Min-Max)			7.1 (3.2 ~ 8.0)	10.0 (4.0 ~ 11.2)	12.5 (5.0 ~ 14.0)	14.0 (5.0 ~ 16.0)
Nominal heating capacity (Min-Max)			8.0 (3.6 ~ 9.0)	11.2 (4.0 ~ 12.5)	14.0 (4.0 ~ 17.0)	16.0 (4.0 ~ 18.0)
Power consumption			2.05 / 2.01	2.68 / 3.02	3.49 / 3.77	4.28 / 4.42
EER/COP			3.46 / 3.98	3.73 / 3.71	3.58 / 3.71	3.27 / 3.62
Inrush current			5	5	5	5
Max. current			17	25	29	30
Sound power level*1	Indoor	Cooling/Heating	65 / 65	65 / 65	67 / 67	70 / 70
	Outdoor	Cooling/Heating	66 / 66	70 / 70	70 / 70	72 / 72
Sound pressure level*1	Indoor	Cooling (P-Hi/Hi/Me/Lo)	38 / 33 / 29 / 25	44 / 38 / 36 / 30	45 / 40 / 34 / 29	47 / 40 / 35 / 30
		Heating (P-Hi/Hi/Me/Lo)	38 / 33 / 29 / 25	44 / 38 / 36 / 30	45 / 40 / 34 / 29	47 / 40 / 35 / 30
	Outdoor	Cooling/Heating	51 / 48	48 / 50	48 / 50	49 / 52
		Cooling/Heating	24 / 19 / 15 / 10	36 / 28 / 25 / 19	39 / 32 / 26 / 20	48 / 35 / 28 / 22
Air flow	Indoor	Cooling (P-Hi/Hi/Me/Lo)	24 / 19 / 15 / 10	36 / 28 / 25 / 19	39 / 32 / 26 / 20	48 / 35 / 28 / 22
		Heating (P-Hi/Hi/Me/Lo)	24 / 19 / 15 / 10	36 / 28 / 25 / 19	39 / 32 / 26 / 20	48 / 35 / 28 / 22
	Outdoor	Cooling/Heating	60 / 50	100 / 100	100 / 100	100 / 100
		Cooling/Heating	60 / 50	100 / 100	100 / 100	100 / 100
External static pressure*2			Pa	Standard:35 Max:200	Standard:60 Max:200	
Exterior dimensions	Indoor	HeightxWidthxDepth	mm	280 x 950 x 635	280 x 1,370 x 740	
	Outdoor	HeightxWidthxDepth	mm	750 x 880(+88) x 340	1,300 x 970 x 370	
Net weight	Indoor		kg	34	54	
	Outdoor		kg	60	105	
Ref.piping size			Liquid/Gas	ømm	9.52(3/8") / 15.88(5/8")	
Refrigerant line (one way) length			m	Max.50	Max.100	
Vertical height differences			Outdoor is higher/lower	m	Max.30 / Max.15	
Outdoor operating temperature range	Cooling	°CDB	-15-43*3			
	Heating	°CWB	-20-20			
Air filter			Procure locally			
Remote control (option)			wired:RC-EX3A, RC-E5, RCH-E3 wireless:RCN-KIT4-E2			

R410A			Hyper Inverter			
Set model name			FDU100VSVXVH	FDU125VSVXVH	FDU140VSVXVH	
Indoor unit			FDU100VH	FDU125VH	FDU140VH	
Outdoor unit			FDC100VVSX	FDC125VVSX	FDC140VVSX	
Power source			3 Phase 380-415V, 50Hz / 380V, 60Hz			
Nominal cooling capacity (Min-Max)			10.0 (4.0 ~ 11.2)	12.5 (5.0 ~ 14.0)	14.0 (5.0 ~ 16.0)	
Nominal heating capacity (Min-Max)			11.2 (4.0 ~ 16.0)	14.0 (4.0 ~ 18.0)	16.0 (4.0 ~ 20.0)	
Power consumption			2.68 / 3.02	3.49 / 3.77	4.28 / 4.42	
EER/COP			3.73 / 3.71	3.58 / 3.71	3.27 / 3.62	
Inrush current			5	5	5	
Max. current			16	18	19	
Sound power level*1	Indoor	Cooling/Heating	65 / 65	67 / 67	70 / 70	
	Outdoor	Cooling/Heating	70 / 70	70 / 70	72 / 72	
Sound pressure level*1	Indoor	Cooling (P-Hi/Hi/Me/Lo)	44 / 38 / 36 / 30	45 / 40 / 34 / 29	47 / 40 / 35 / 30	
		Heating (P-Hi/Hi/Me/Lo)	44 / 38 / 36 / 30	45 / 40 / 34 / 29	47 / 40 / 35 / 30	
	Outdoor	Cooling/Heating	48 / 50	48 / 50	49 / 52	
		Cooling/Heating	36 / 28 / 25 / 19	39 / 32 / 26 / 20	48 / 35 / 28 / 22	
Air flow	Indoor	Cooling (P-Hi/Hi/Me/Lo)	36 / 28 / 25 / 19	39 / 32 / 26 / 20	48 / 35 / 28 / 22	
		Heating (P-Hi/Hi/Me/Lo)	36 / 28 / 25 / 19	39 / 32 / 26 / 20	48 / 35 / 28 / 22	
	Outdoor	Cooling/Heating	100 / 100	100 / 100	100 / 100	
		Cooling/Heating	100 / 100	100 / 100	100 / 100	
External static pressure*2			Pa	Standard:60 Max:200		
Exterior dimensions	Indoor	HeightxWidthxDepth	mm	280 x 1,370 x 740		
	Outdoor	HeightxWidthxDepth	mm	1,300 x 970 x 370		
Net weight	Indoor		kg	54		
	Outdoor		kg	105		
Ref.piping size			Liquid/Gas	ømm	9.52(3/8") / 15.88(5/8")	
Refrigerant line (one way) length			m	Max.100		
Vertical height differences			Outdoor is higher/lower	m	Max.30 / Max.15	
Outdoor operating temperature range	Cooling	°CDB	-15-43*3			
	Heating	°CWB	-20-20			
Air filter			Procure locally			
Remote control (option)			wired:RC-EX3A, RC-E5, RCH-E3 wireless:RCN-KIT4-E2			

## SPECIFICATIONS -FDU-

R32			Micro Inverter		
Set model name			FDU100VNAWVH	FDU125VNAWVH	FDU140VNAWVH
Indoor unit			FDU100VH	FDU125VH	FDU140VH
Outdoor unit			FDC100VNA-W	FDC125VNA-W	FDC140VNA-W
Power source			1 Phase 220-240V, 50Hz / 220V, 60Hz		
Nominal cooling capacity (Min~Max)			kW 10.0 ( 4.0 ~ 11.2 )	12.5 ( 5.0 ~ 14.0 )	13.6 ( 5.0 ~ 14.5 )
Nominal heating capacity (Min~Max)			kW 11.2 ( 4.0 ~ 12.5 )	14.0 ( 4.0 ~ 16.0 )	15.5 ( 4.0 ~ 16.5 )
Power consumption			Cooling/Heating kW 2.99 / 2.66	4.36 / 3.69	5.13 / 4.21
EER/COP			Cooling/Heating 3.35 / 4.21	2.87 / 3.79	2.65 / 3.68
Inrush current			A 5	5	5
Max. current			26	26	27
Sound power level*1	Indoor	Cooling/Heating	65 / 65	67 / 67	70 / 70
	Outdoor	Cooling/Heating	69 / 70	71 / 71	72 / 73
Sound pressure level*1	Indoor	Cooling (P-Hi/Hi/Me/Lo)	dB(A) 44 / 38 / 36 / 30	45 / 40 / 34 / 29	47 / 40 / 35 / 30
		Heating (P-Hi/Hi/Me/Lo)		45 / 40 / 34 / 29	47 / 40 / 35 / 30
	Outdoor	Cooling/Heating	54 / 55	54 / 56	56 / 58
		Air flow	Indoor	Cooling (P-Hi/Hi/Me/Lo)	m³/min 36 / 28 / 25 / 19
		Heating (P-Hi/Hi/Me/Lo)	36 / 28 / 25 / 19	39 / 32 / 26 / 20	
	Outdoor	Cooling/Heating	75 / 73	75 / 73	75 / 73
External static pressure*2			Pa	Standard:60 Max:200	
Exterior dimensions	Indoor	HeightxWidthxDepth	mm	280 x 1,370 x 740	
	Outdoor			845 x 970 x 370	
Net weight	Indoor		kg	54	
	Outdoor			77	
Ref.piping size			Liquid/Gas	ømm 9.52(3/8") / 15.88(5/8")	
Refrigerant line (one way) length			m	Max.50	
Vertical height differences			Outdoor is higher/lower	Max.50 / Max.15	
Outdoor operating temperature range			Cooling	°CDB -15~50*3	
			Heating	°CWB -20~20	
Air filter			Procure locally		
Remote control (option)			wired:RC-EX3A, RC-E5, RCH-E3 wireless:RCN-KIT4-E2		

R32			Micro Inverter		
Set model name			FDU100VSAWVH	FDU125VSAWVH	FDU140VSAWVH
Indoor unit			FDU100VH	FDU125VH	FDU140VH
Outdoor unit			FDC100VSA-W	FDC125VSA-W	FDC140VSA-W
Power source			3 Phase 380-415V, 50Hz / 380V, 60Hz		
Nominal cooling capacity (Min~Max)			kW 10.0 ( 4.0 ~ 11.2 )	12.5 ( 5.0 ~ 14.0 )	13.6 ( 5.0 ~ 14.5 )
Nominal heating capacity (Min~Max)			kW 11.2 ( 4.0 ~ 12.5 )	14.0 ( 4.0 ~ 16.0 )	15.5 ( 4.0 ~ 16.5 )
Power consumption			Cooling/Heating kW 2.99 / 2.66	4.36 / 3.69	5.13 / 4.21
EER/COP			Cooling/Heating 3.35 / 4.21	2.87 / 3.79	2.65 / 3.68
Inrush current			A 5	5	5
Max. current			17	17	18
Sound power level*1	Indoor	Cooling/Heating	65 / 65	67 / 67	70 / 70
	Outdoor	Cooling/Heating	69 / 70	71 / 71	72 / 73
Sound pressure level*1	Indoor	Cooling (P-Hi/Hi/Me/Lo)	dB(A) 44 / 38 / 36 / 30	45 / 40 / 34 / 29	47 / 40 / 35 / 30
		Heating (P-Hi/Hi/Me/Lo)		45 / 40 / 34 / 29	47 / 40 / 35 / 30
	Outdoor	Cooling/Heating	54 / 55	54 / 56	56 / 58
		Air flow	Indoor	Cooling (P-Hi/Hi/Me/Lo)	m³/min 36 / 28 / 25 / 19
		Heating (P-Hi/Hi/Me/Lo)	36 / 28 / 25 / 19	39 / 32 / 26 / 20	
	Outdoor	Cooling/Heating	75 / 73	75 / 73	75 / 73
External static pressure*2			Pa	Standard:60 Max:200	
Exterior dimensions	Indoor	HeightxWidthxDepth	mm	280 x 1,370 x 740	
	Outdoor			845 x 970 x 370	
Net weight	Indoor		kg	54	
	Outdoor			78	
Ref.piping size			Liquid/Gas	ømm 9.52(3/8") / 15.88(5/8")	
Refrigerant line (one way) length			m	Max.50	
Vertical height differences			Outdoor is higher/lower	Max.50 / Max.15	
Outdoor operating temperature range			Cooling	°CDB -15~50*3	
			Heating	°CWB -20~20	
Air filter			Procure locally		
Remote control (option)			wired:RC-EX3A, RC-E5, RCH-E3 wireless:RCN-KIT4-E2		

### NOTES:

<p>The data are measured under the following conditions(R32 : ISO-T1, -H1 /, R410A : ISO-T1).  Cooling:Indoor temp. of 27°CDB, 19°CWB, and outdoor temp. of 35°CDB. Heating:Indoor temp. of 20°CDB, and outdoor temp. of 7°CDB, 6°CWB.  *1 : Indicates the value in an anechoic chamber. During operation these values are somewhat higher due to ambient conditions.  *2 : External static pressure is changeable to be set by the remote control. MAX external static pressure is "High static pressure" setting. The values of sound pressure level become 5dB(A) higher at external static pressure of 200Pa.  *3 : If a cooling operation is conducted when the outdoor air temperature is -5°C or lower, the outdoor unit should be installed at a place where it is not influenced by natural wind. If wind blows, the low pressure will drop and compressor frequency will increase, this will cause the capacity to drop and may cause the unit to break down.  *4 : In case of following conditions:Max.50m(Outdoor unit is higher &amp; Outdoor temperature 43°C), Max.30m(Outdoor unit is higher &amp; Outdoor temperature &gt; 43°C)</p>
---

R32			Micro Inverter		
Set model name			FDU200VSAWVH	FDU250VSAWVH	FDU280VSAWVH
Indoor unit			FDU200VH	FDU250VH	FDU280VH
Outdoor unit			FDC200VSA-W	FDC250VSA-W	FDC280VSA-W
Power source			3 Phase 380-415V, 50Hz / 380V, 60Hz		
Nominal cooling capacity (Min-Max)			kW 20.0 ( 7.2 ~ 22.4 )	25.0 ( 6.9 ~ 28.0 )	27.0 ( 6.9 ~ 31.5 )
Nominal heating capacity (Min-Max)			kW 22.4 ( 6.5 ~ 25.0 )	28.0 ( 6.7 ~ 31.5 )	31.5 ( 6.9 ~ 33.5 )
Power consumption			Cooling/Heating kW 6.15 / 5.67	8.25 / 7.55	9.15 / 9.13
EER/COP			Cooling/Heating 3.25 / 3.95	3.03 / 3.75	2.95 / 3.45
Inrush current			A 5	5	5
Max. current			23	25	25
Sound power level*1	Indoor	Cooling/Heating	78 / 78	78 / 78	78 / 78
	Outdoor	Cooling/Heating	72 / 74	73 / 75	75 / 77
Sound pressure level*1	Indoor	Cooling (P-Hi/Hi/Me/Lo)	52 / 50 / 47 / 45	52 / 50 / 47 / 45	52 / 50 / 47 / 45
	Indoor	Heating (P-Hi/Hi/Me/Lo)	52 / 50 / 47 / 44	52 / 50 / 47 / 44	52 / 50 / 47 / 44
Air flow	Indoor	Cooling (P-Hi/Hi/Me/Lo)	80 / 72 / 64 / 56	80 / 72 / 64 / 56	80 / 72 / 64 / 56
	Indoor	Heating (P-Hi/Hi/Me/Lo)	80 / 72 / 64 / 56	80 / 72 / 64 / 56	80 / 72 / 64 / 56
Outdoor	Cooling/Heating	m <sup>3</sup> /min 148 / 134	148 / 153	136 / 140	
External static pressure*2			Pa	Standard:72 Max:200	
Exterior dimensions	Indoor	HeightxWidthxDepth	mm	379 x 1,600 x 893	
	Outdoor		1,505 x 970 x 370		
Net weight	Indoor		kg	88	
	Outdoor		144	145	155
Ref.piping size	Liquid/Gas	ømm	9.52(3/8") / 25.4(1") 12.7(1/2") / 25.4(1")		
Refrigerant line (one way) length			m	Max.70 Max.60	
Vertical height differences			Outdoor is higher/lower	m Max.50*4 / Max.15	
Outdoor operating temperature range	Cooling	°CDB	-15~50*3		
	Heating	°CWB	-20~20		
Air filter			Procure locally		
Remote control (option)			wired:RC-EX3A, RC-E5, RCH-E3 wireless:RCN-KIT4-E2		

R410A			Micro Inverter		
Set model name			FDU100VNAVH	FDU125VNAVH	FDU140VNAVH
Indoor unit			FDU100VH	FDU125VH	FDU140VH
Outdoor unit			FDC100VNA	FDC125VNA	FDC140VNA
Power source			1 Phase 220-240V, 50Hz / 220V, 60Hz		
Nominal cooling capacity (Min-Max)			kW 10.0 ( 4.0 ~ 11.2 )	12.5 ( 5.0 ~ 14.0 )	13.6 ( 5.0 ~ 14.5 )
Nominal heating capacity (Min-Max)			kW 11.2 ( 4.0 ~ 12.5 )	14.0 ( 4.0 ~ 16.0 )	15.5 ( 4.0 ~ 16.5 )
Power consumption			Cooling/Heating kW 2.84 / 2.78	4.36 / 3.69	4.93 / 4.21
EER/COP			Cooling/Heating 3.52 / 4.03	2.87 / 3.79	2.76 / 3.68
Inrush current			A 5	5	5
Max. current			26	26	27
Sound power level*1	Indoor	Cooling/Heating	65 / 65	67 / 67	70 / 70
	Outdoor	Cooling/Heating	70 / 70	71 / 71	73 / 73
Sound pressure level*1	Indoor	Cooling (P-Hi/Hi/Me/Lo)	44 / 38 / 36 / 30	45 / 40 / 34 / 29	47 / 40 / 35 / 30
	Indoor	Heating (P-Hi/Hi/Me/Lo)	44 / 38 / 36 / 30	45 / 40 / 34 / 29	47 / 40 / 35 / 30
Air flow	Indoor	Cooling (P-Hi/Hi/Me/Lo)	36 / 28 / 25 / 19	39 / 32 / 26 / 20	48 / 35 / 28 / 22
	Indoor	Heating (P-Hi/Hi/Me/Lo)	36 / 28 / 25 / 19	39 / 32 / 26 / 20	48 / 35 / 28 / 22
Outdoor	Cooling/Heating	m <sup>3</sup> /min 75 / 73	75 / 73	75 / 73	
External static pressure*2			Pa	Standard:60 Max:200	
Exterior dimensions	Indoor	HeightxWidthxDepth	mm	280 x 1,370 x 740	
	Outdoor		845 x 970 x 370		
Net weight	Indoor		kg	54	
	Outdoor		80		
Ref.piping size	Liquid/Gas	ømm	9.52(3/8") / 15.88(5/8")		
Refrigerant line (one way) length			m	Max.50	
Vertical height differences			Outdoor is higher/lower	m Max.50 / Max.15	
Outdoor operating temperature range	Cooling	°CDB	-15~50*3		
	Heating	°CWB	-20~20		
Air filter			Procure locally		
Remote control (option)			wired:RC-EX3A, RC-E5, RCH-E3 wireless:RCN-KIT4-E2		



## SPECIFICATIONS -FDU-

R410A			Micro Inverter		
Set model name			FDU100VSAVH	FDU125VSAVH	FDU140VSAVH
Indoor unit			FDU100VH	FDU125VH	FDU140VH
Outdoor unit			FDC100VSA	FDC125VSA	FDC140VSA
Power source			3 Phase 380-415V, 50Hz / 380V, 60Hz		
Nominal cooling capacity (Min-Max)			kW 10.0 ( 4.0 ~ 11.2 )	12.5 ( 5.0 ~ 14.0 )	13.6 ( 5.0 ~ 14.5 )
Nominal heating capacity (Min-Max)			kW 11.2 ( 4.0 ~ 12.5 )	14.0 ( 4.0 ~ 16.0 )	15.5 ( 4.0 ~ 16.5 )
Power consumption			Cooling/Heating kW 2.84 / 2.78	4.36 / 3.69	4.93 / 4.21
EER/COP			Cooling/Heating 3.52 / 4.03	2.87 / 3.79	2.76 / 3.68
Inrush current			A 5	5	5
Max. current			17	17	18
Sound power level*1	Indoor	Cooling/Heating	65 / 65	67 / 67	70 / 70
	Outdoor	Cooling/Heating	70 / 70	71 / 71	73 / 73
Sound pressure level*1	Indoor	Cooling (P-Hi/Hi/Me/Lo)	dB(A) 44 / 38 / 36 / 30	45 / 40 / 34 / 29	47 / 40 / 35 / 30
		Heating (P-Hi/Hi/Me/Lo)			
	Outdoor	Cooling/Heating	54 / 56	55 / 57	57 / 59
Air flow	Indoor	Cooling (P-Hi/Hi/Me/Lo)	m³/min 36 / 28 / 25 / 19	39 / 32 / 26 / 20	48 / 35 / 28 / 22
		Heating (P-Hi/Hi/Me/Lo)			
	Outdoor	Cooling/Heating	75 / 73	75 / 73	75 / 73
External static pressure*2			Pa	Standard:60 Max:200	
Exterior dimensions	Indoor	HeightxWidthxDepth	mm	280 x 1,370 x 740	
	Outdoor			845 x 970 x 370	
Net weight	Indoor		kg	54	
	Outdoor			82	
Ref.piping size			Liquid/Gas	ømm 9.52(3/8") / 15.88(5/8")	
Refrigerant line (one way) length			m	Max.50	
Vertical height differences			Outdoor is higher/lower	Max.50 / Max.15	
Outdoor operating temperature range			Cooling	°CDB -15~50*3	
			Heating	°CWB -20~20	
Air filter			Procure locally		
Remote control (option)			wired:RC-EX3A, RC-E5, RCH-E3 wireless:RCN-KIT4-E2		

R410A			Micro Inverter		
Set model name			FDU200VSAVH	FDU250VSAVH	
Indoor unit			FDU200VH	FDU250VH	
Outdoor unit			FDC200VSA	FDC250VSA	
Power source			3 Phase 380-415V, 50Hz / 380V, 60Hz		
Nominal cooling capacity (Min-Max)			kW 19.0 ( 5.2 ~ 22.4 )	24.0 ( 6.9 ~ 28.0 )	
Nominal heating capacity (Min-Max)			kW 22.4 ( 3.3 ~ 25.0 )	27.0 ( 5.5 ~ 31.5 )	
Power consumption			Cooling/Heating kW 6.15 / 6.03	7.98 / 7.20	
EER/COP			Cooling/Heating 3.09 / 3.71	3.01 / 3.75	
Inrush current			A 5	5	
Max. current			25	27	
Sound power level*1	Indoor	Cooling/Heating	78 / 78	78 / 78	
	Outdoor	Cooling/Heating	72 / 74	73 / 75	
Sound pressure level*1	Indoor	Cooling (P-Hi/Hi/Me/Lo)	dB(A) 52 / 50 / 47 / 45	52 / 50 / 47 / 45	
		Heating (P-Hi/Hi/Me/Lo)			
	Outdoor	Cooling/Heating	58 / 59	59 / 62	
Air flow	Indoor	Cooling (P-Hi/Hi/Me/Lo)	m³/min 80 / 72 / 64 / 56	80 / 72 / 64 / 56	
		Heating (P-Hi/Hi/Me/Lo)			
	Outdoor	Cooling/Heating	135 / 135	143 / 151	
External static pressure*2			Pa	Standard:72 Max:200	
Exterior dimensions	Indoor	HeightxWidthxDepth	mm	379 x 1,600 x 893	
	Outdoor			1,300 x 970 x 370	
Net weight	Indoor		kg	88	
	Outdoor			143	
Ref.piping size			Liquid/Gas	ømm 9.52(3/8") / 25.4(1")	
Refrigerant line (one way) length			m	Max.70	
Vertical height differences			Outdoor is higher/lower	Max.30 / Max.15	
Outdoor operating temperature range			Cooling	°CDB -15~50*3	
			Heating	°CWB -15~20	
Air filter			Procure locally		
Remote control (option)			wired:RC-EX3A, RC-E5, RCH-E3 wireless:RCN-KIT4-E2		

### NOTES:

<p>The data are measured under the following conditions(R32 : ISO-T1, -H1 / R410A : ISO-T1).  Cooling:Indoor temp. of 27°CDB, 19°CWB, and outdoor temp. of 35°CDB. Heating:Indoor temp. of 20°CDB, and outdoor temp. of 7°CDB, 6°CWB.  *1 : Indicates the value in an anechoic chamber. During operation these values are somewhat higher due to ambient conditions.  *2 : External static pressure is changeable to be set by the remote control. MAX external static pressure is "High static pressure" setting. The values of sound pressure level become 5dB(A) higher at external static pressure of 200Pa.  *3 : If a cooling operation is conducted when the outdoor air temperature is -5°C or lower, the outdoor unit should be installed at a place where it is not influenced by natural wind. If wind blows, the low pressure will drop and compressor frequency will increase, this will cause the capacity to drop and may cause the unit to break down.</p>
--

R32			Standard Inverter		
Set model name			FDU71VNPVH	FDU90VNPVH	FDU100VNPVH
Indoor unit			FDU71VH	FDU100VH	FDU100VH
Outdoor unit			FDC71VNP-W	FDC90VNP-W	FDC100VNP-W
Power source			1 Phase 220-240V, 50Hz / 220V, 60Hz		
Nominal cooling capacity (Min-Max)			7.1 (1.5 ~ 7.3)	9.0 (2.1 ~ 9.5)	10.0 (2.1 ~ 10.2)
Nominal heating capacity (Min-Max)			7.1 (1.1 ~ 7.3)	9.0 (1.7 ~ 9.5)	10.0 (1.7 ~ 10.4)
Power consumption			2.60 / 1.89	2.62 / 1.98	3.08 / 2.45
EER/COP			2.73 / 3.76	3.44 / 4.55	3.25 / 4.08
Inrush current			5	5	5
Max. current			15.8	19	19
Sound power level*1	Indoor	Cooling/Heating	65 / 65	65 / 65	65 / 65
	Outdoor	Cooling/Heating	67 / 67	67 / 66	68 / 67
Sound pressure level*1	Indoor	Cooling (P-Hi/Hi/Me/Lo)	38 / 33 / 29 / 25	44 / 38 / 36 / 30	44 / 38 / 36 / 30
		Heating (P-Hi/Hi/Me/Lo)	38 / 33 / 29 / 25	44 / 38 / 36 / 30	44 / 38 / 36 / 30
	Outdoor	Cooling/Heating	54 / 54	55 / 53	56 / 54
		Cooling (P-Hi/Hi/Me/Lo)	24 / 19 / 15 / 10	36 / 28 / 25 / 19	36 / 28 / 25 / 19
Air flow	Indoor	Heating (P-Hi/Hi/Me/Lo)	24 / 19 / 15 / 10	36 / 28 / 25 / 19	36 / 28 / 25 / 19
		Cooling/Heating	42 / 42	59 / 55	63 / 55
External static pressure*2			Pa	Standard:35 Max:200	Standard:60 Max:200
Exterior dimensions	Indoor	HeightxWidthxDepth	mm	280 x 950 x 635	280 x 1,370 x 740
	Outdoor			640 x 800(+71) x 290	750 x 880(+88) x 340
Net weight	Indoor		kg	34	54
	Outdoor			45	57
Ref.piping size			Liquid/Gas	ømm	6.35(1/4") / 12.7(1/2")
Refrigerant line (one way) length			m	Max.30	Max.30
Vertical height differences			Outdoor is higher/lower	m	Max.20 / Max.20
Outdoor operating temperature range	Cooling	°CDB		-15~46*3	
	Heating	°CWB		-15~20	
Air filter				Procure locally	
Remote control (option)				wired:RC-EX3A, RC-E5, RCH-E3 wireless:RCN-KIT4-E2	

R410A			Standard Inverter		
Set model name			FDU71VNPVH	FDU90VNP1VH	FDU100VNP1VH
Indoor unit			FDU71VH	FDU100VH	FDU100VH
Outdoor unit			FDC71VNP	FDC90VNP1	FDC100VNP
Power source			1 Phase 220-240V, 50Hz / 220V, 60Hz		
Nominal cooling capacity (Min-Max)			7.1 (1.4 ~ 7.1)	9.0 (1.9 ~ 9.0)	10.0 (2.8 ~ 11.2)
Nominal heating capacity (Min-Max)			7.1 (1.0 ~ 7.1)	9.0 (1.5 ~ 9.0)	11.2 (2.5 ~ 12.5)
Power consumption			2.60 / 1.89	2.69 / 2.25	3.00 / 2.93
EER/COP			2.73 / 3.76	3.35 / 4.00	3.33 / 3.82
Inrush current			5	5	5
Max. current			14.5	18	22
Sound power level*1	Indoor	Cooling/Heating	65 / 65	65 / 65	65 / 65
	Outdoor	Cooling/Heating	67 / 67	69 / 69	70 / 70
Sound pressure level*1	Indoor	Cooling (P-Hi/Hi/Me/Lo)	38 / 33 / 29 / 25	44 / 38 / 36 / 30	44 / 38 / 36 / 30
		Heating (P-Hi/Hi/Me/Lo)	38 / 33 / 29 / 25	44 / 38 / 36 / 30	44 / 38 / 36 / 30
	Outdoor	Cooling/Heating	54 / 54	57 / 55	57 / 61
		Cooling (P-Hi/Hi/Me/Lo)	24 / 19 / 15 / 10	36 / 28 / 25 / 19	36 / 28 / 25 / 19
Air flow	Indoor	Heating (P-Hi/Hi/Me/Lo)	24 / 19 / 15 / 10	36 / 28 / 25 / 19	36 / 28 / 25 / 19
		Cooling/Heating	36 / 36	63 / 49.5	75 / 79
External static pressure*2			Pa	Standard:35 Max:200	Standard:60 Max:200
Exterior dimensions	Indoor	HeightxWidthxDepth	mm	280 x 950 x 635	280 x 1,370 x 740
	Outdoor			640 x 800(+71) x 290	750 x 880(+88) x 340
Net weight	Indoor		kg	34	54
	Outdoor			45	70
Ref.piping size			Liquid/Gas	ømm	6.35(1/4") / 12.7(1/2")
Refrigerant line (one way) length			m	Max.30	Max.30
Vertical height differences			Outdoor is higher/lower	m	Max.20 / Max.20
Outdoor operating temperature range	Cooling	°CDB		-15~46*3	
	Heating	°CWB		-15~20	
Air filter				Procure locally	
Remote control (option)				wired:RC-EX3A, RC-E5, RCH-E3 wireless:RCN-KIT4-E2	